



“Made in Fujitec”

Fujitec is Creating and Leading the
New Global Standard for Elevators



By manufacturing safe and reliable elevators in-house, we are building trust with people around the world.

Fujitec's "Global Common Components" are used in the REXIA-D brand. The quality of components, such as traction machines, elevator controllers, and operating fixtures, is controlled through Fujitec's integrated system of global quality management. Elevators with the same high quality will be provided by Fujitec's global supply chain under the concept of "Made in Fujitec."



Excellent Performance

The permanent magnetic synchronous gearless motors, which have been designed and developed by Fujitec, provide the utmost reliability and excellent driving performance. These motors reflect 75 years of accumulated know-how through our technological achievements in elevator manufacturing, which spans from product designing to fabrication.



Reliable Operation

Since all control-related components, ranging from control circuits to inverters, were independently developed by Fujitec, highly reliable elevator operation is established. In the event of an elevator malfunction, the elevator control system assembled with our components immediately detects the malfunction and maintains efficient and stable operation.

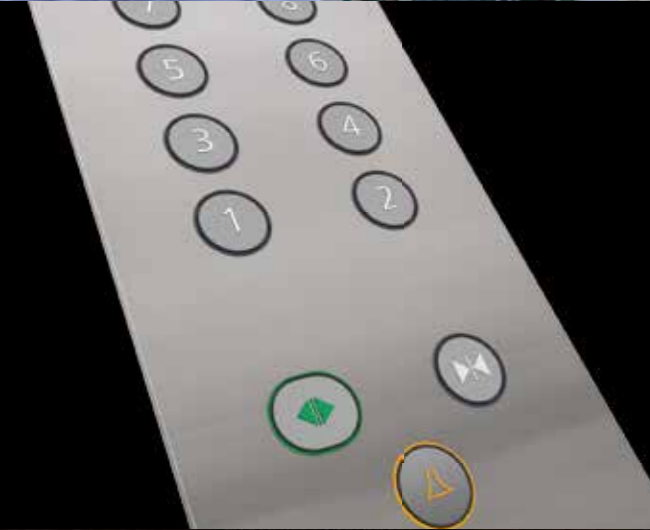

Universal Design

Under our universal designs, aesthetically refined buttons, displays, etc. on elevator operating fixtures are highly visible. Passengers will have a superb and comfortable riding experience.



Styles

Various decoration styles for the elevator interior and landing floors are offered by Fujitec. Customers can select the most suitable decorative materials for car panels, car ceilings, car floorings, car operating boards and landing fixtures.



CONTENTS

Excellent Performance05	
Reliable Operation..... 06	
Universal Design..... 07	
Styles..... 09	
Systems & Functions..... 25	
Planning..... 29	
Relevant Dimensions..... 33	
Power Supply Data..... 34	
Work Done by Others 35	

Excellent Performance

Gearless Traction Machine with Permanent Magnetic Synchronous Motor

The gearless traction machine with a permanent magnet synchronous motor assure high riding comfort quality and low power consumption. This newly adopted technology reduces the weight and size of a traction machine, because gears are no longer required for elevator speed control.

No Elevator Machine Room Results in Space Saving

Our REXIA-D elevator requires no machine room space. This remarkable feature results in a reduction of building construction cost and allows building architects to maximize floor design without needing to factor in machine rooms of conventional elevator.

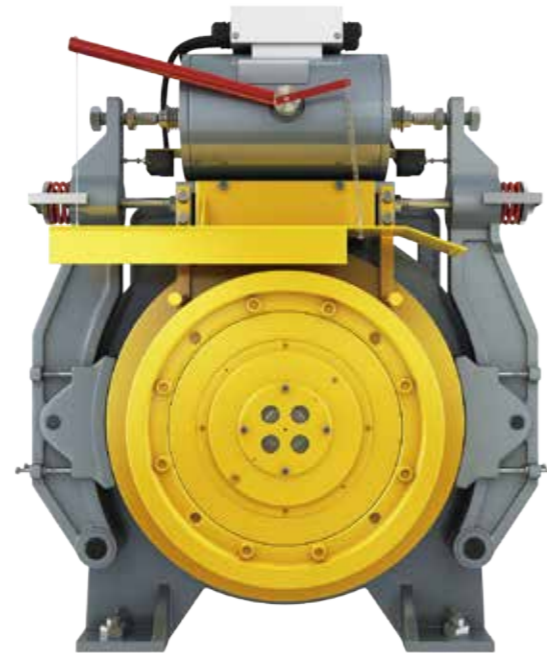
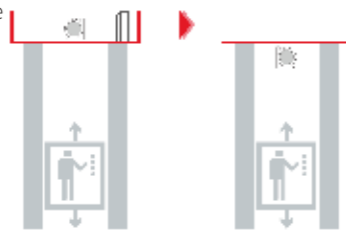

Ultra-Slim Door Operator with Permanent Magnetic Synchronous Motor

Fujitec's new door operators have adopted a permanent magnetic synchronous motor which doesn't have any gears for door speed control. The use of this kind of motor reduces the size of a door operator and achieves smooth and precise door operation.

These new door operators consume approximately **35%** less power than the conventional ones.



- A 32-bit data bus provides high-speed and high-precision data transmission of input-output command signals between each microprocessor located in control panels, hall-call / car-call buttons, hall indicators and hall lanterns.

- High-speed data transmis with multiple protocols enables large-scale data processing at ten times the normal speed. This also improves the ability to monitor elevator running speed, landing precision and operating reliability as well as input-output command signals of car operating fixtures and operation indicators.

- The bus system is employed for data transmission between microcomputers located in every hall-call fixture, car operating board, and control panel. This bus system has strong protection against signal interference and has system-extending capability.



An elevator operation system with multiple microcomputers makes maximum use of the "Distributed Control System." Hall indicators, car operating boards, and control panels incorporate high-performance microcomputers. These independent microcomputers analyze elevator operating conditions utilizing self-diagnostic functions and implement immediate control of elevator operations. Also, data transmission buses among microcomputers increase data processing capability.

Distributed Control System

COP: Control Panel
COB: Car Operating Board
MIC: Microcomputer
IN: Hall Indicator

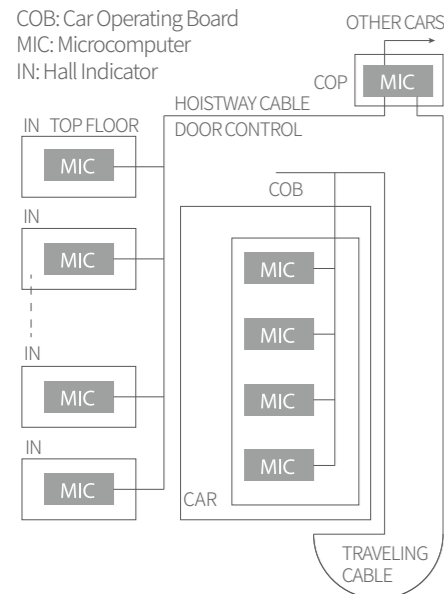

Reliable Operation



Car Door Anti Stripping Device

It can prevent passengers from falling into the hoistway when the door is opened in the non-unlocking area, and further ensure the safety of elevator passengers.



Impact Resistant Door System

The impact resistance of the landing door system is further strengthened, and the risk of falling into the hoistway caused by the impact of the landing door system is effectively prevented, further ensuring the safety of elevator related personnel.



Unintended Car Movement Protection (UCMP)

A safety-purpose control circuit independent of the elevator operating system detects unintended movement of a car and prevents the car from moving from the floor with its doors open. This function improves passenger safety.

FLEX-NX series - Elevator Group Supervisory Control System -

Fujitec has adopted the "Virtual Passenger Optimization Method" as a new elevator group control system.

This system controls elevator group operation by virtually calculating passenger waiting time in advance based on past accumulated data, such as passenger travel patterns and passenger volume at each floor. Also, this method comprehensively calculates passenger waiting time based on extrapolated data of probable future passengers, how many passengers will come to a certain floor when a hall call is registered and/or how many passengers will come to a certain floor when no hall call is registered. This comprehensive analysis reflects whole building traffic conditions for efficient elevator operation control as well as reducing daily passenger waiting time by up to 10%.

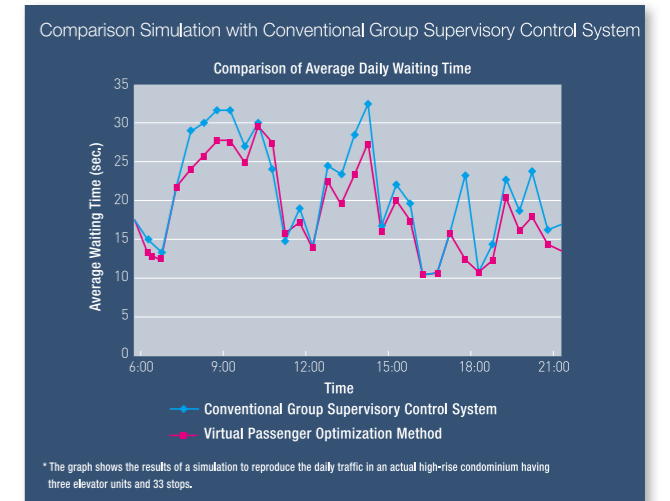



Fujitec's new global-standard operating fixtures reflect the latest in Human Engineering technology. Fixture buttons with clearly visible lettering function as the man-machine interface. Passengers can register their destination in a visually intuitive manner.

23569 23569

The newly adopted lettering for the operating fixture buttons is highly visible at wider angles than the former one. The lettering is highly visible, so that passengers anywhere under any lighting conditions in the car can see and easily read the letters and the numbers. Fujitec's uniquely designed operating fixtures function as a friendly interface between the passengers and the elevators.

The eye-catching green door open button can prevent passengers from mistaking the door open button for other buttons.

The emergency call button is located about 900mm from floor level allowing children and physically impaired to use in case of emergency.



Night-Time Self-Checking Operation

- A safety enhancement for increased reliability -

Mechanical brake conditions are automatically checked by moving the elevator during the night time while not receiving any car and hall calls.

This night-time self-checking operation increases passenger safety and contributes to a high after-sales product quality.

IONFUL

- Plasmacluster™ Ion Generating Device -

(Optional Specification)

Fujitec is the leading elevator company to have installed a Plasmacluster Ion generating device in an elevator. This device built in a car's ventilating unit disinfects airborne mold, bacteria, viruses, allergens, and odor molecules as well as creating clean air in the elevator which enhances passenger comfort.

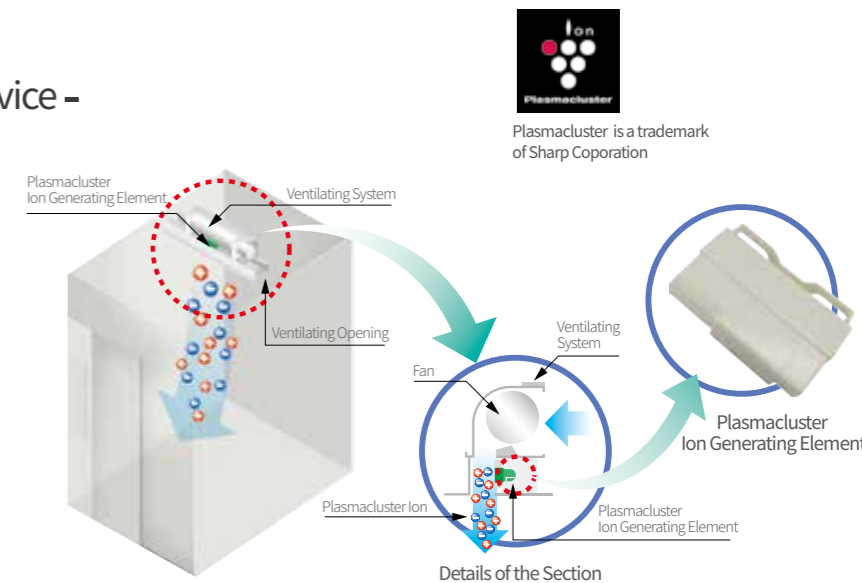

Plasmacluster is a trademark of Sharp Corporation

Multi-Beam Sensor

Multi-beam Sensor emits multiple infrared beams, creating an invisible curtain covering the doorway. If any of the beams is interrupted, the closing doors will stop and reopen. This function results in a significantly higher detection rate of a passenger and/or an object in the doorway.



LED Down Lights on Car Ceiling

For car ceiling lighting, Fujitec adopts LED downlights, which are long-lasting and energy-efficient. This adoption contributes to the protection of the environment.

	approx. 1,500 hours	approx. 20,000 hours	approx. 13 times
Lifetime			
Wattage	90W	9W	1/10(one-tenth)



VONIC (Automatic Voice Announcement System)

(Optional Specification)

A computerized voice system (English) provides passengers with timely information about car directions, car arrivals, door opening and closing, and emergencies, etc.

[At the customer's request, announcements in other languages can be added.]





Ceiling:
CE-g1
Paint Finished Steel Sheet
(TE-a7)

Walls,Transom &Door:
Paint Finished Steel Sheet
(TE-a7)

Fan:
Cross-Flow Fan

Car Operating Board:
(FX-h1) Stainless Steel with
Hairline

Floor: BD-b2

Sill: Stainless Steel

**Car Floor (Option)
(PVC Tiles)**



BD-b1



BD-b2

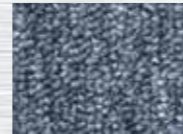

BD-b3



BD-b4



BD-b5



BD-b6



BD-b7



BD-b8



Ceiling: Stainless Steel with Hairline Finish (Frame)
(CE-e4) Stainless Steel with Mirror Finish (Central)

Walls,Transom &Door: Stainless Steel with Hairline Finish

Fan: Cross-Flow Fan

COB: FX-k11

Floor: Designed PVC (BD-C1)

Sill: Stainless Steel



Ceiling: Paint Finished Steel Sheet (TE-f1)
(CE-e2)

Walls,Transom &Door: Stainless Steel with Hairline Finish

Mirror: Stainless Steel with Mirror Finish

Fan: Cross-Flow Fan

Handrail: HR-a1

WCOB: FX-g31

Floor: Designed PVC (BD-C1)

Sill: Stainless Steel



Ceiling: (CE-c1)	Paint Finished Steel Sheet (TE-f1)
Walls,Transom &Door:	Stainless Steel with Hairline Finish
Fan:	Cross-Flow Fan
Floor:	BD-b5
Sill:	Stainless Steel



Ceiling: (CE-e4)	Stainless Steel with Hairline Finish (Frame) Stainless Steel with Mirror Finish (Central)
Walls(CR-f2):	
Side Panel:	Steel Panel with Wooden Decorative Plate(Sides) Stainless Steel with Mirror Finish(Centra)
Rear Panel:	Steel Panel with Wooden Decorative Plate(Sides) Patterned Glass + Light Strip (Centra)
Front Panel, Transom :	Stainless Steel with Hairline Finish
Fan:	Cross-Flow Fan
Floor:	Designed PVC (BD-C1)
Sill:	Stainless Steel



Steel Panel with Wooden Decorative Plate



Ceiling: (CE-g5)	Stainless Steel with Mirror Finish
Walls(CR-f1):	
Side & Rear Panels:	Steel Plate with Laminated Sheet(TE-g1)
Wall's Centra Panels:	Stainless Steel with Mirror Finish
Front Panel,Transom:	Stainless Steel with Sandblast Finish
Door:	Stainless Steel with Sandblast Finish
Fan:	Cross-Flow Fan
Floor:	Designed PVC (BD-b8)
Sill:	Stainless Steel
Kick Plate:	Stainless Steel with Hairline Finish



Ceiling: (CE-e2)	Stainless Steel with Mirror Finish
Walls(CR-f1):	
Side & Rear Panels:	Steel Plate with Laminated Sheet(TE-g2)
Wall's Centra Panels:	Stainless Steel with Mirror Finish
Front Panel,Transom:	Stainless Steel with Sandblast Finish
Door:	Stainless Steel with Sandblast Finish
Fan:	Cross-Flow Fan
Floor:	Designed PVC (BD-b6)
Sill:	Stainless Steel
Kick Plate:	Stainless Steel with Hairline Finish

Optional Car Design

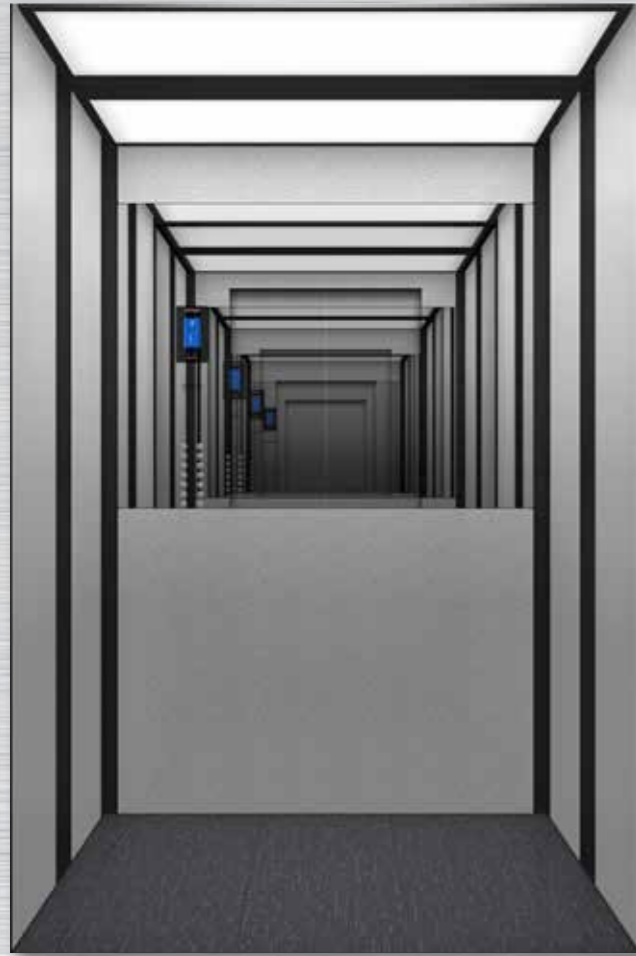

Ceiling: (CE-c5)	Paint Finished Steel Sheet (Dark Gray with Sand Texture)
Walls(CR-f3):	
Side Panels:	Light Gray Satin Coated Steel Plate Black Satin Coated Steel Plate
Rear Panel:	Light Gray Satin Coated Steel Plate Black Satin Coated Steel Plate Mirror
Front Panel, Transom:	Stainless Steel with Mirror Finish
Fan:	Cross-Flow Fan
Floor:	BD-b6
Car Operating Board:	FX-k13
Sill:	Aluminum Alloy



Ceiling: (CE-e4)	Stainless Steel with Hairline Finish (Frame) Stainless Steel with Mirror Finish (Central)
Walls(CR-f4):	
Side Panels:	Steel Plate with Laminated Sheet(TE-g1)
Rear Panel:	Stainless Steel with Mirror Finish (Two sides), Stainless Steel with Mirror Etching Finish (Central)
Front Panel, Transom :	Stainless Steel with Hairline Finish
Fan:	Cross-Flow Fan
Floor:	Designed PVC (BD-e1)
Sill:	Aluminum Alloy



CE-g1

Flat Panel:
Steel Sheet with Color Paint
Light :
LED (White)
Emergency Light (1W, LED)

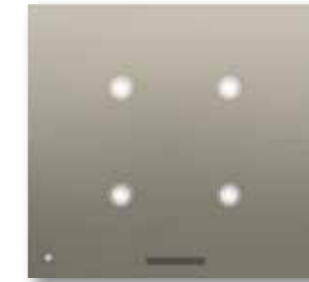

CE-g5

Flat Panel:
Steel Sheet with Color Paint
Light :
Downlight (10W, LED)
Emergency Light(1W,LED)



CE-c1

Arch-Shaped Part:
Milky-White Acrylic Sheet
Flat Part:
Steel Sheet with Color Paint
Light:
LED+ Downlight(3W, LED)
Emergency Light(5W,LED)

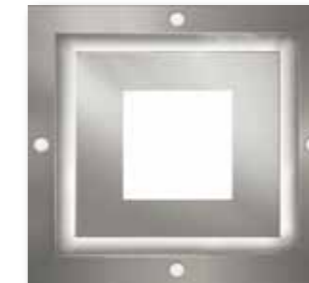

CE-e2

Frame Part:
Stainless Steel with Hairline
Central Part:
Stainless Steel with Mirror
Milky- White Acrylic Sheet
Light:
LED(White)+ Downlight(2W, LED)
Emergency Light(4.5W, LED)

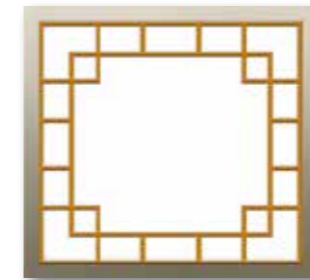

CE-c7

Flat Part:
Milky-White Acrylic Sheet
Flat Panel:
Steel Sheet with Color Paint
Light:
LED (White)
Emergency Light(5W,LED)



CE-e5

Flat Panel:
Milky-White Acrylic Sheet
Flat Panel:
Paint Finished Steel Sheet
- Dark Gray with Sand Texture
Light :
LED (White)



CE-c4

Arch-Shaped Part:
Milky-White Acrylic Sheet
Flat Part:
Steel Sheet with Color Paint
Light:
LED (White)
Emergency Light(5W,LED)

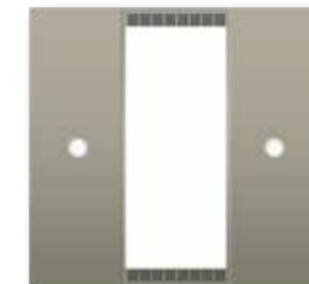

CE-e2

Arch-Shaped Part:
Milky-White Acrylic Sheet
Flat Panel:
Steel Sheet with Color Paint
Light:
LED (White)+ Downlight(3W, LED)
Emergency Light(4.5W, LED)
(In case of deep car, the design of ceiling will be changed.)

Design of CE-e2 for Deep Car:
The layout rotate by 90°.



■ Standard ■ Optional

Note: Ceiling internal height will vary based on the ceiling types.

FX-h1



Faceplate:
Stainless Steel with Hairline Finish
Indicator:
Orange Dot-Matrix LED
Buttons:
Push buttons

FX-h12



Faceplate:
Stainless Steel with Hairline Finish
Indicator:
Monochrome LCD Screen (7 inch)
Buttons:
Push buttons

FX-h11



Optional Background

Faceplate:
Stainless Steel with Hairline Finish
Indicator:
Multicolor LCD Screen (7 inch)
Buttons:
Push buttons

Wall-mounted Type

FX-h4



FX-h5



FX-h7



FX-h8



FX-h6



FX-h41



FX-h51



FX-h71



FX-h42



FX-h52



FX-h72



Faceplate:
Stainless Steel with Hairline Finish/ Acrylic Resin
Indicator:
Orange Dot-Matrix LED
Multicolor LCD Screen (4.2 inch)
Monochrome LCD (4.1 inch)
Buttons:
Push buttons

■ Standard ■ Optional

FX-k1



Faceplate: (Swing Type)
Stainless Steel with Hairline Finish
Indicator:
Orange Dot-Matrix LED
Buttons:
Push buttons

FX-k11



Faceplate: (Swing Type)
Stainless Steel with Hairline Finish
Indicator:
Multicolor LCD Screen (7 inch)
Buttons:
Push buttons

FX-k12



Faceplate: (Swing Type)
Stainless Steel with Hairline Finish
Indicator:
Multicolor LCD Screen (10.4 inch)
Buttons:
Push buttons

FX-k13



Faceplate: (Swing Type)
Stainless Steel with Hairline Finish
Indicator:
Monochrome LCD Screen (7 inch)
Buttons:
Push buttons

Inserted Box Type

FX-k4



FX-k5



FX-k7



FX-k6



FX-k76



FX-k41



FX-k51



FX-k71



FX-k42



FX-k52



FX-k72



FX-k73



7 inch Multicolor LCD

Standard Optional



Faceplate:
Stainless Steel with Hairline Finish
Indicator:
Orange Dot-Matrix LED
Multicolor LCD Screen (4.2 inch)
Monochrome LCD (4.1 inch)
Buttons:
Push buttons

Note: FX-k1, FX-k11, FX-k12, FX-k13 might be not available depend on the car size.

FX-n41



FX-n51



FX-n71



FX-n6



FX-g32



CP-D3

Type: Stainless Steel Button with Braille Dots
When Pressed: Light Emitting Part: Ring
Lighting Color: Orange

Faceplate: Stainless Steel with Hairline Finish
Buttons: Stainless Steel Button



FX-n42



FX-n52



FX-n72



FX-n43



FX-n53



FX-n73



FX-n74



FX-n54



FX-n44



The surface of stainless steel is nano-anti-fingerprint treatment, which realizes the anti-fingerprint effect and greatly improves the anti-dirty.

Faceplate: Fingerprint Resistant Sandblasted Stainless Steel
Indicator: Multicolor LCD Screen (4.3 inch)
Monochrome LCD (5.0 inch)
Buttons: Push buttons

*It is cost-free to replace by common stainless steel with hairline finish.

Button



CP-D4

Type: Stainless Steel Button
Ring & Number emits light: Slight white light when standby, strong white light when answering.



CP-D5

Type: Stainless Steel Button with Braille Dots
Ring & Number emits light: Slight white light when standby, strong white light when answering.



RP-D1

Type: Stainless Steel Button
When Pressed: Light Emitting Part: Ring
Lighting Color: Orange



RP-D3

Type: Stainless Steel Button with Braille Dots
When Pressed: Light Emitting Part: Ring
Lighting Color: Orange



RP-E4

Type: Glass Button
Square & Number emits light: Slight white light when standby, blue light when answering.



CP-D1

Type: Stainless Steel Button
When Pressed: Light Emitting Part: Ring
Lighting Color: Orange

Handrail



HR-a1
Stainless Steel Hairline Plate



HR-b1 & b2
Stainless Steel Hairline Tube/ Stainless Steel Mirror Tube

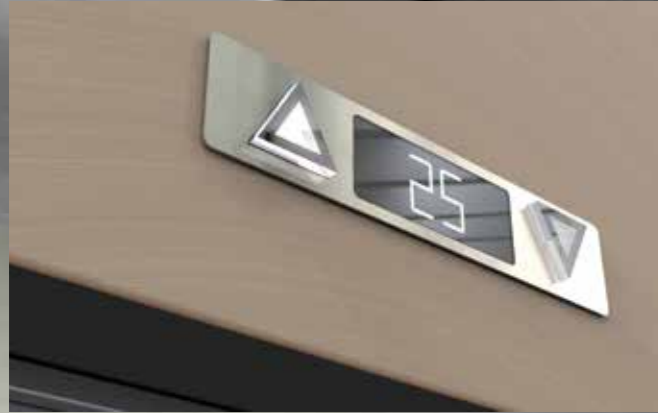

FX-k74

Size (mm)
L440x W90 x H8
Indicator
LED
Lighting Color
White



FX-k75

Size (mm)
L440 x W100 x H14.5
Indicator
LCD (4.3 inch)
Lighting Color
Yellow



FX-k8

Size (mm)
L60 x W200 x H46
Lighting Color
Yellow



FX-k81

Size (mm)
L55 x W422 x H26
Lighting Color
Yellow



FX-k82

Size (mm)
L55 x W422 x H46.5
Lighting Color
Yellow

Hall Button + Hall-Lantern combination without the Hall (Digital/LCD) Indicator is recommended when 4GSO- 8GSO* is operated by the <Immediate Announcement System of a serving Car> function is applied by FLEX- NX (202 & 300).
(* GSO = Group Supervisory Operation)



1 Car



2 Cars



Group Supervisory Control

TE-a9	TE-a7	Ceilings, Car Panels, Car Doors, Landing Doors and Jamb: Paint	
TE-b1	TE-b2	<small>Note: The colors of TE-f1 and TE-f2 are optional. *Actual colors may differ from the images.</small>	
TE-f1	TE-f2		
TE-g1	TE-g2	TE-g3	TE-g4
TE-g5	Car Side & Rear Panels: Steel Plate with Laminated Sheet		
<small>*Actual colors may differ from the images.</small>			
YS-001	YS-004	YS-007	YS-008
YS-015	YS-025	YS-026	YS-059
Car Panels, Car Doors and Landing Doors: Stainless Steel with Etching			
<small>*The dimensions of an actual pattern differ from the images.</small>			
BD-b1	BD-b2	BD-b3	BD-b4
Car Floor (Vinyl Tile)			
<small>*The scale and color of an actual design differs from the images.</small>			
BD-b5	BD-b6	BD-b7	BD-b8
BD-b9	BD-b10	BD-b11	
BD-e1	BD-e2	BD-c1	BD-c3
Car Floor (Designed PVC)			
<small>*The scale and color of an actual design differs from the images.</small>			

REXIA-D Main Specifications

Capacity*

800kg, 1000kg, 1200kg, 1350kg,
1600kg, 2000kg

Speed*

1.0m/s, 1.5m/s, 1.75m/s, 2.0m/s,
2.5m/s

Number of Served Floors

30 Stops or Less

Travel Height Main Specifications

80m or less

Control Method

VVVF controlled by distributed
32-bit Microcomputers.

Traction Machine

Gearless Machine with Permanent
Magnetic Synchronous Motor

Types of Elevator Operation

1-Car or 2-Car Selective Collective
Operation or Group Control Operation
for 4 Cars in a Bank

Door Operation System

Permanent Magnetic Gearless
Motor controlled by VVVF

Door Opening Type

2-Panel Center Opening

*Note: The elevator of 1600kg, 2000kg load capacity is
equipped with 2-Panel Side Opening door as standard for
deep car.*

* If the load capacity is greater than 2000kg or the speed is greater than 2m/s, please contact Fujitec sales person.

The above specifications may change without prior notice.

1. Elevator Operation Control System

Control Systems	Details of the Systems
For One Elevator: 1-Car Selective Collective Operation (Simplex)	Landing calls in the direction in which the elevator is traveling are served sequentially. After all the landing calls are served, landing calls in the opposite direction will be served. When there are no incoming calls, the elevator stops and stays at the last served floor.
For Two Elevators in a Bank: 2-Car Selective Collective Operation (Duplex)	Two selective-collective-operation elevators work together in one group. Landing calls are served by either elevator that can respond first. When there are no calls, one will be on standby at the main floor; the other will stay at the last served floor.
For Three to Four Elevators in a Bank (Group Control Operation)	The operation of more than two elevators in a bank is controlled by a group supervisory system which calculates passenger waiting time in advance based on the accumulated traffic data, such as passenger travel patterns and passenger volume at each floor, etc.

2. Functions and Specific-Purpose Operations, etc.

Functions and Specific-Purpose Operations, etc.	Details	●: Standard / ■: Optional		
		●	■	
Alarm Buzzer	When the emergency button is pressed, the car-top-mounted buzzer will sound an alarm.	●		
Rescue Operation to the Nearest Floor	In the event that an elevator stops between floors, a safety circuit will automatically analyze the situation and slowly move the elevator to the nearest available floor.	●		
Automatic Releveling	In the event that an elevator floor isn't leveled with the landing floor, the Automatic Releveling function will initiate and make the elevator floor flush with the landing floor.	●		
Emergency Car Lighting	In the event of a power failure, a self-charging-battery-equipped emergency lighting system will light up the elevator for passenger safety and relief.	●		
Five-Way Intercom	An intercom for 5-way communication is installed in the elevator. It allows 4 remote telephones to communicate with the elevator; one on the car top, one in the pit, one in the machine room and one in the building-system control room.	●		
Passenger-Safety Functions	Multi-Beam Sensor	A multi-beam sensor emits multiple infrared beams, which will scan at the high speed in the elevator door, forming an infrared beam barrier. If a single beam is interrupted, the sensor will stop the closing doors and reopen them.	●	
	Multi-Beam Sensor with Mechanical Safety Edge	A multiple-beam sensor can be incorporated in mechanical safety edges of elevator doors.		■
	Night-Time Self-Checking Operation	During the night time when the elevator doesn't receive any car and hall calls, the system will move the elevator and check the mechanical brake conditions automatically.	●	
	Open Door Warning	If a passenger tries to forcibly open the doors while the elevator is in operation, the warning device will sound an alarm.	●	
	Unintended Car Movement Protection (UCMP)	The Unintended Car Movement Protection system prevents elevator movement from the landing floor, while passengers are entering and getting off the elevator.	●	
	Car Door Anti Stripping Device	It can prevent passengers from falling into the hoistway when the door is opened in the non- unlocking area, and further ensure the safety of elevator passengers.	●	
	Impact Resistant Door System	The impact resistance of the landing door system is further strengthened, and the risk of falling into the hoistway caused by the impact of the landing door system is effectively prevented, further ensuring the safety of elevator related personnel.	●	

The above functions may change without prior notice.

Systems & Functions

Functions and Specific-Purpose Operations, etc.		Details	●: Standard / ■: Optional	
Efficient-Operation Functions	Anti-Nuisance Function	1) For elevators with three or more landings, when three or more car calls are registered at the same time, or when four or more car calls are registered in an extremely short period of time, the system will automatically cancel the activated car calls. 2) For elevators with five or more landings, when an elevator loaded with 100 kg or less receives four or more car call registrations, the system will cancel all the activated registrations.	●	
	Auto Adjustment of Door Open Time	This function automatically adjusts the door-hold open time (dwell time) at each floor depending on passengers' hall- and car- call registration situations.	●	
	Automatic Return to Main Floor (for 1-Car & 2-Car & Group Control Operation)	When an elevator does not receive any car- or hall- calls for a certain period of time, the Automatic Return to Main Floor function makes the elevator go to the lobby or a predetermined floor and waits in standby for passengers to board.	●	
	Door Nudging	If the car doors are held open over a given period of time, the Door Nudging function will close them slowly with an audible alarm.	●	
	Auto-Separation after Elevator Failure (for Group Control Operation)	When an elevator under group control operation fails to operate normally, it will be separated from the elevator group so as not to affect the overall group elevator performance.	●	
	Load Bypass	When a traveling car is fully loaded, it will bypass floors where hall calls are registered. Those hall calls will be assigned to another available elevator.		■
	Overload Warning	When a car becomes overloaded, the warning alarm will sound. The elevator doors will not close until the overloaded state is resolved.	●	
	Reverse-Direction Car-Call Cancellation	In the event that a passenger tries to register a car call that is behind the car's current travelling direction, the elevator system will regard it as a nuisance call and ignore it in order to maintain the elevator service efficiency.	●	
	Wrong Car-Call Register Cancellation	In case a passenger presses the wrong car call button, this mistake can be cancelled by pushing the same button twice.	●	
	Door Open Holding Button (COB)	In order to meet the demand of loading and unloading goods, a door opening extension button is installed on the operation panel in the car. Pressing this button can keep the door opening time for 3 minutes.		■
Passenger-Comfort Functions	Arrival Chime (In Car)	When a car arrives at a destination floor, an arrival chime will sound softly.		■
	Attendant Operation	By using attendant-operation buttons inside a car operating board's cabinet, authorized personnel can register car calls for in-car passengers. In addition to monitoring incoming hall calls, the attendant decides the car travel direction and operates the car doors with priority service for in-car passengers.	●	
	Automatic Voice Announcement System (VONIC)	A computerized voice system provides passengers with timely information about car directions, car arrivals, door opening and closing, and emergencies, etc. At the customer's request, announcements in other languages can be added.		■
	Plasmacluster™ Ion Generating Device (IONFUL)	Plasmacluster Ion Generating Device to be built into a car's ventilation unit creates clean air for passenger comfort by disinfecting germs, odor molecules, bacteria, viruses, and allergens in the elevator.		■
	Visual Display on Car Operating Board	Informing on an elevator's current condition, a visual display on the car operating board will provide passengers with timely text messages such as "OVERLOADED", "EMER. OPERATION", "PLEASE EXIT THE ELEVATOR." etc,	●	
	Visual Display on Landing Fixture	Informing on an elevator's current condition, a visual display on the landing fixture will provide waiting passengers with timely text messages such as "OVERLOADED", "EMER. OPERATION", etc.	●	

Functions and Specific-Purpose Operations, etc.		Details	●: Standard / ■: Optional	
Energy-Saving Functions	Automatic Fan and Light Control	If an elevator receives no car- and hall- calls within a certain period of time, its ventilation fan and lights will turn off automatically.	●	
	Elevator Operation Period Control	The elevator operation period in a day is automatically controlled by a timer mounted on the control panel's computer board in the machine room.		■
	Parking Operation	When an elevator is shifted to Parking Operation mode, the elevator will move to the pre-assigned floor and park with its doors closed, and car lights and fan turned off.		■
Specific-Purpose Operations	Battery-Powered Automatic Landing Operation (LANDIC)	In the event of a power failure, a compact battery power source will move the car to the nearest available floor.		■
	Door Opening Failure Rescue Operation	When an elevator fails to open the doors at a landing floor, it will move to the next available floor and open them.	●	
	Earthquake Rescue Operation (WAVIC)	When a seismic sensor has detected a seismic wave (the secondary seismic wave), the elevator(s) will be shifted to rescue operation mode and automatically move to the nearest available floor for passenger evacuation.		■
	Fire Operation	In the event of a fire, the Fire Operation mode will automatically take an elevator directly to a refuge floor and immobilize it there. (One refuge floor at the terminal floor)	●	
	Fireman Operation	Under automatic operation, when the Fireman's switch is on, the car will immediately cancel all the calls and run to the refuge floor. The elevator responds to the call in the car only, which is used for special fire fighting operation.		■
	Independent Operation	By turning on the Independent Operation buttons (EXCL) inside a car operating board's cabinet, the elevator only responds the car-calls, and does not respond the hall-calls.	●	
	Standby Power Operation	In the event of a power failure, the elevator(s) will return to an refuge floor using standby power and will be held there on standby. * Standby power system shall be provided and installed by third parties.		■
	Equipment for Building Security, etc.	Elevator Visual Monitoring System (ELVIC)	By monitoring the current status of running elevators and giving necessary commands to elevators through desk-top PCs in a specific remote location, ELVIC manages and controls elevator operation.	
CCTV-Camera Cables		To meet the needs of video capture or digital signal transmission such as surveillance cameras in the car, the elevator is equipped with dedicated transmission cables from the COP to the car, which can respond to various transmission schemes according to the needs of the building party.		■
Elevator Operation Supervisory Panel (such as watching board, console panel, etc.)		Through an elevator operation supervisory panel, the status of elevator operation can be monitored and controlled.		■
Building-Management-System (BMS) Interface		Through a purpose-built interface, a building management system can receive up-to-date elevator operation data.		■

The above functions may change without prior notice.

Planning

1600Kg, 2000kg 2-Panel Right Side Opening Door (2SR)

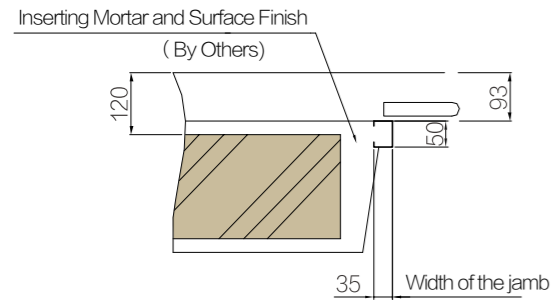

(left Side of the Narrow Jamb)

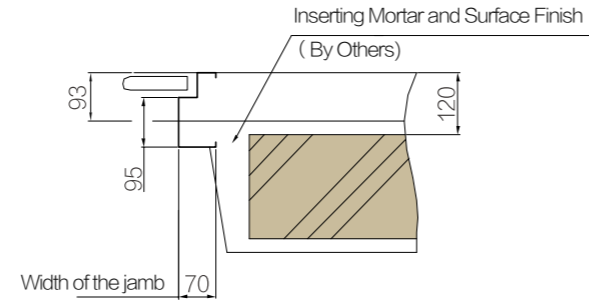

(Right Side of the Narrow Jamb)

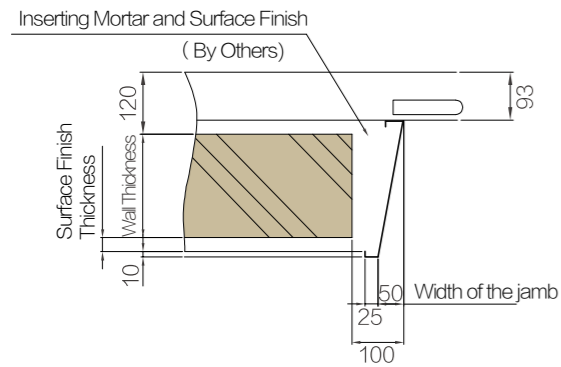

(left Side of the Wide Jamb)

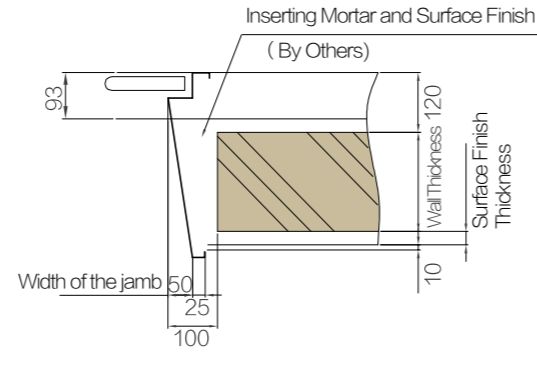

(Right Side of the Wide Jamb)

800-2000Kg 2-Panel Center Opening(2CO)

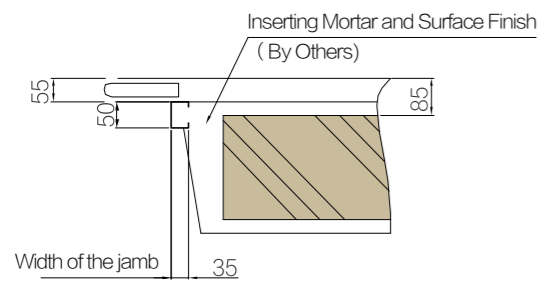

Narrow Jamb

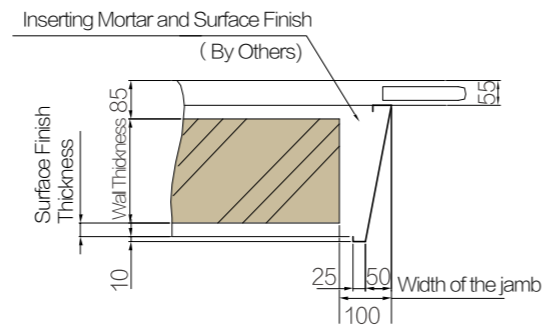

Wide Jamb

Note: The above dimensions are for reference only. The actual engineering design data shall be used.

Standard Specification (Wall-Mounted Type)

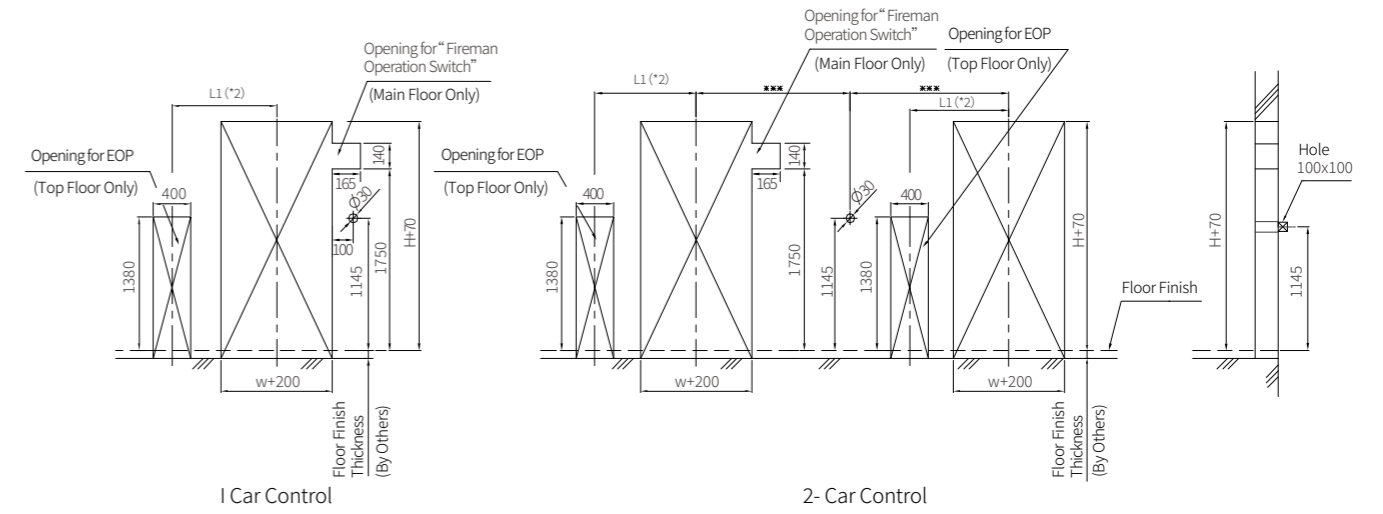

Optional Specification (Inserted Box Type)

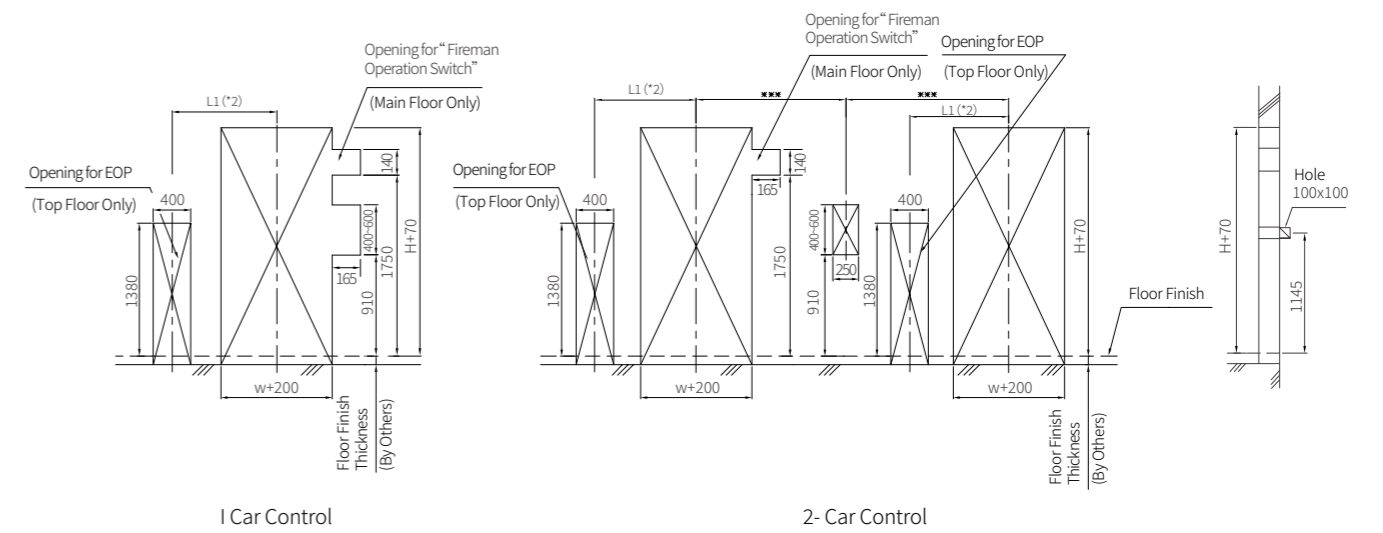

Note 1: The above dimensions are for reference only. The actual engineering design data shall be used.

Note 2:

Capacity (kg)	800 (Wide Car)	800 (Deep Car)	1000 (Wide Car)	1000 (Deep Car)	1200 (Wide Car)	1200 (Deep Car)	1350 (Wide Car)	1350 (Deep Car)	1600 (Wide Car)	1600 (Deep Car)	2000 (Wide Car)	2000 (Deep Car)
L1(mm)	885	760	1010	775	1150	825	1245	825	1300	1140	1470	1220

Planning

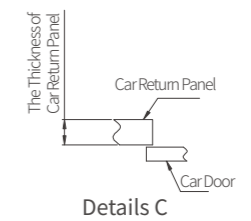
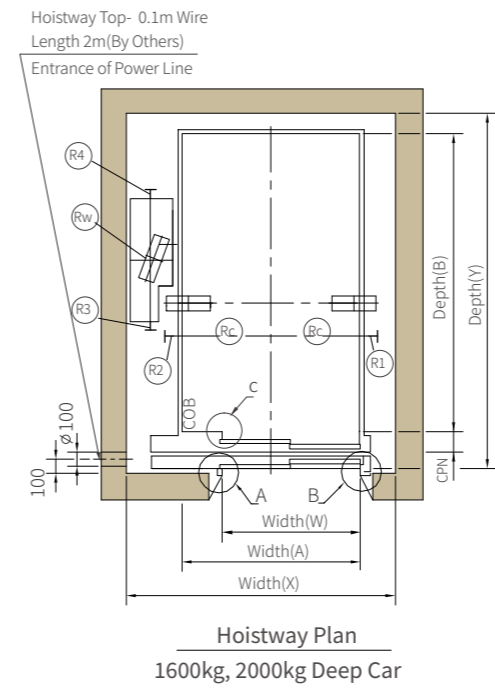
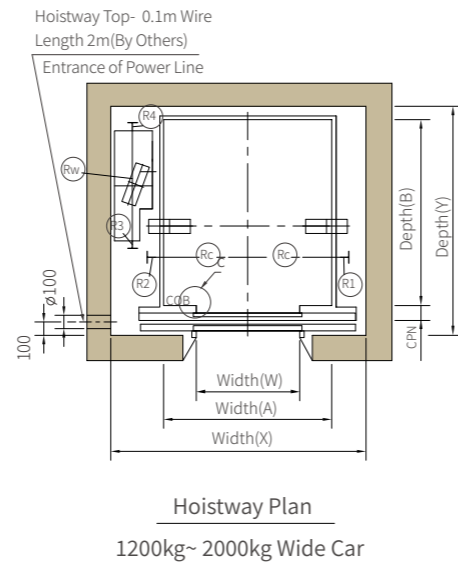
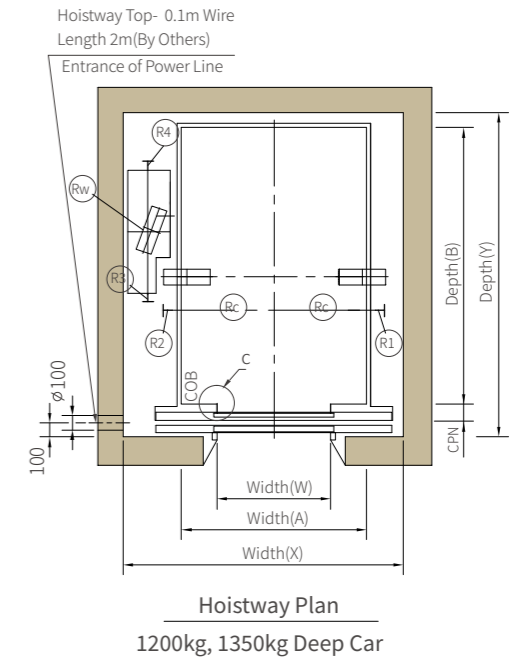
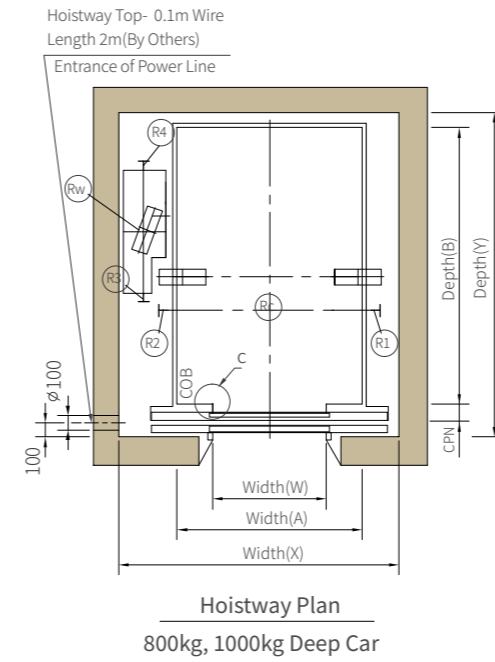
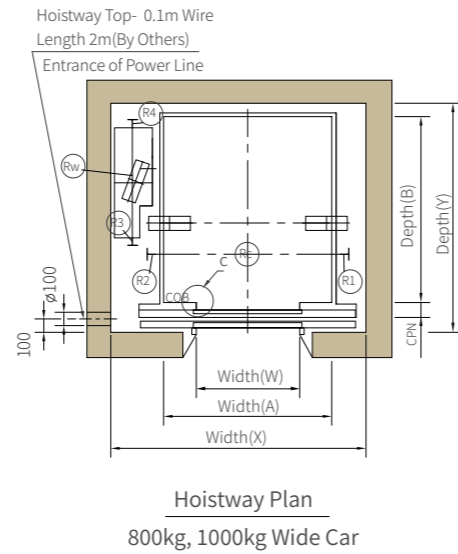
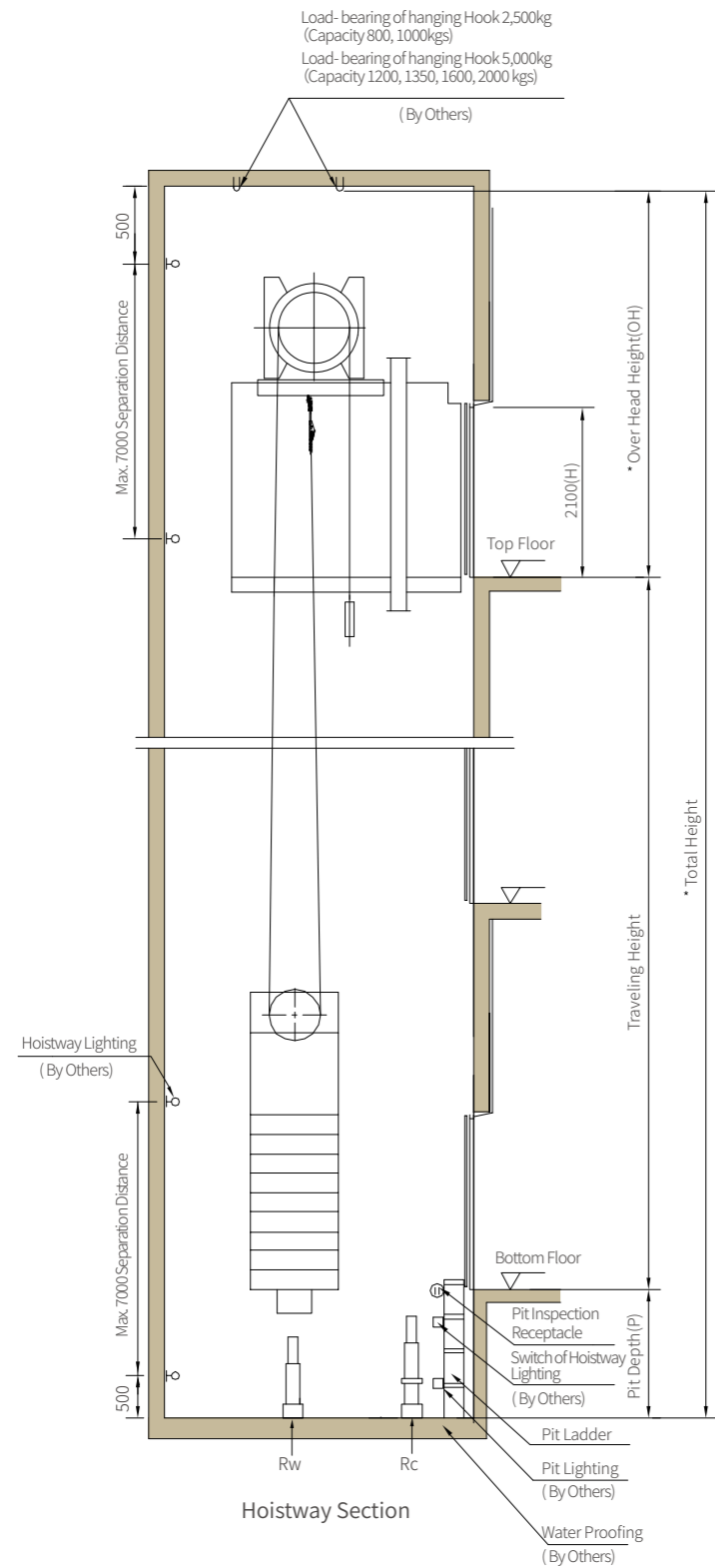

*1. The above dimensions are for reference only. The actual engineering design data shall be used.
 *2. The above dimensions are based on RC-structure hoistway.
 *3. The above hoistway's internal dimensions are based on the hoistway with waterproof finish.
 *4. If hoistway's internal dimensions are too large, intermediate beams shall be provided and installed by others based on Fujitec-submitted drawings.
 *5. The required thickness of the hoistway's structural walls is 150mm or more (not including the thickness of wall finish).

Relevant Dimensions

Power Supply Data

Wide Car

Capacity (kg)	Speed (m/s)	Opening Type	Car Inside A x B (mm)	Opening W x H (mm)	Hoistway X x Y (mm)	Pit Depth P (mm)	Overhead OH (mm)	Pit Reaction (kN)					
								Rc	Rw	R1	R2	R3	R4
800	1.0	2CO	1350x1400	800x2100	1985x1700	1280	CPH+1380	100	84	52	52	71	49
	1.5					1370	CPH+1500						
	1.75					1420	CPH+1590						
	2.0					1500	CPH+1700						
	2.5					1700	CPH+1950						
1000	1.0	2CO	1600x1400	900x2100	2200x1700	1280	CPH+1380	116	96	56	56	78	53
	1.5					1370	CPH+1500						
	1.75					1420	CPH+1590						
	2.0					1600	CPH+1700						
	2.5					1750	CPH+1950						
1200	1.0	2CO	1800x1500	1100x2100	2550x1810	1340	CPH+1400	67	100	72	72	113	76
	1.5					1490	CPH+1580						
	1.75					1540	CPH+1700						
	2.0					1600	CPH+1800						
	2.5					1800	CPH+2000						
1350	1.0	2CO	2000x1500	1100x2100	2650x1810	1450	CPH+1400	77	126	78	78	124	83
	1.5					1570	CPH+1580						
	1.75					1700	CPH+1680						
	2.0					1700	CPH+1800						
	2.5					1900	CPH+2000						
1600	1.0	2CO	2100x1600	1100x2100	2755x1900	1450	CPH+1400	94	155	83	83	130	91
	1.5					1600	CPH+1580						
	1.75					1700	CPH+1680						
	2.0					1700	CPH+1800						
	2.5					1900	CPH+2000						
2000	1.0	2CO	2350x1700	1200x2100	3050x2000	1450	CPH+1450	107	173	92	92	144	102
	1.5					1650	CPH+1580						
	1.75					1720	CPH+1680						
	2.0					1720	CPH+1800						
	2.5					1900	CPH+2000						

Deep Car

Capacity (kg)	Speed (m/s)	Opening Type	Car Inside A x B (mm)	Opening W x H (mm)	Hoistway X x Y (mm)	Pit Depth P (mm)	Overhead OH (mm)	Pit Reaction (kN)					
								Rc	Rw	R1	R2	R3	R4
800	1.0	2CO	1100x1800	800x2100	1860x2100	1280	CPH+1380	100	84	52	52	71	49
	1.5					1370	CPH+1500						
	1.75					1420	CPH+1590						
	2.0					1500	CPH+1700						
	2.5					1700	CPH+1950						
1000	1.0	2CO	1100x2100	900x2100	1950x2400	1280	CPH+1380	116	96	56	56	78	53
	1.5					1370	CPH+1500						
	1.75					1420	CPH+1590						
	2.0					1600	CPH+1700						
	2.5					1750	CPH+1950						
1200	1.0	2CO	1300x2100	900x2100	2000x2400	1340	CPH+1400	67	100	72	72	113	76
	1.5					1490	CPH+1580						
	1.75					1540	CPH+1700						
	2.0					1600	CPH+1800						
	2.5					1800	CPH+2000						
1350	1.0	2CO	1300x2300	900x2100	2000x2600	1450	CPH+1400	77	126	78	78	124	83
	1.5					1570	CPH+1580						
	1.75					1700	CPH+1680						
	2.0					1700	CPH+1800						
	2.5					1900	CPH+2000						
1600	1.0	2SL	1400x2400	1200x2100	2200x2770	1450	CPH+1400	94	155	83	83	130	91
	1.5					1600	CPH+1580						
	1.75					1700	CPH+1680						
	2.0					1700	CPH+1800						
	2.5					1900	CPH+2000						
2000	1.0	2SL	1500x2700	1200x2100	2270x3080	1450	CPH+1450	107	173	92	92	144	102
	1.5					1650	CPH+1580						
	1.75					1720	CPH+1680						
	2.0					1720	CPH+1800						
	2.5					1900	CPH+2000						

- Notes: 1. The data shown above may vary based on elevator specification arrangement.
 2. Refer to the Work Done by Others for the Acceptable Inclination of Hoistway's Vertical Centerline.
 3. The standard car panel height is 2350mm.
 4. The standard thickness of car return panel is 55 mm. It can be increased to 90 mm for the beautiful appearance with free cost, the precondition is that the depth size of hoistway and machine room should be added 35mm based on above.

Capacity (kg)	Speed (m/s)	Motor Power (kW)	Rated Current (A)	Acceleration Current (A)	Equivalent Current (A)	Power Capacity (kVA)	Open Circuit Current (A)	Allowable Maximum Length of Main Power Feeder Line(m)									
								25mm ²	35mm ²	50mm ²	70mm ²	95mm ²	120mm ²	150mm ²	185mm ²	240mm ²	300mm ²
800	1.0	5.2	19	28	7	8	20	343	468	613	830	1073	1506	1807	2119	2575	2711
	1.5	7.8	27	43	9	11	32	237	323	423	573	740	1039	1247	1463	1777	1871
	1.75	9	30	48	9	12	32	217	296	388	526	679	953	1144	1342	1631	1717
	2.0	10.4	34	57	10	14	40	191	260	341	462	597	837	1005	1179	1432	1508
	2.5	13.6	41	74	12	16	50	157	214	280	380	491	690	828	971	1179	1242
1000	1.0	6.5	23	33	9	9	25	281	383	502	680	878	1233	1480	1735	2109	2220
	1.5	9.7	32	50	10	13	40	198	270	354	480	620	870	1044	1225	1488	1567
	1.75	11.4	35	55	11	15	40	182	249	326	442	571	802	962	1129	1372	1444
	2.0	13	39	64	12	16	40	162	221	290	393	507	712	854	1002	1218	1282
	2.5	17	54	95	16	20	63	119	162	213	288	373	523	628	736	895	942
1200	1.0	8.2	27	40	11	11	32	235	320	419	568	734	1031	1237	1451	1763	1856
	1.5	12.2	40	62	13	15	40	162	221	289	392	507	711	853	1001	1216	1280
	1.75	14.2	45	73	14	17	50	141	192	251	341	440	618	742	870	1057	1113
	2.0	16.3	51	84	15	20	63	126	172	225	305	395	554	665	780	948	998
	2.5	19.5	59	103	17	22	63	109	148	194	264	341	478	574	673	818	861
1350	1.0	9.6	30	45	12	12	32	211	287	377	510	659	926	1111	1303	1583	1667
	1.5	13.7	45	72	15	17	50	143	195	256	347	448	629	755	886	1076	1133
	1.75	16	48	78	15	19	50	132	181	237	321	414	582	698	819	995	1048
	2.0	18	56	94	17	22	63	114	156	204	276	357	502	602	706	858	903
	2.5	22.3	70	129	21	25	80	91	124	162	220	284	399	479	561	682	718
1600	1.0	10.9	33	46	13	14	40	197	269	352	477	616	865	1039	1218	1480	1558
	1.5	16.2	49	74	16	20	50	129	177	231	314	405	569	683	801	974	1025
	1.75	19	54	83	16	22	63	118	162	212	287	371	521	625	733	891	938
	2.0	21.8	59	94	17	25	63	106	144	189	257	332	466	559	656	797	839
	2.5	27.2	77	131	21	31	80	83	113	148	200	259	364	437	512	622	655
2000	1.0	13.6	38	54	16	16	40	166	227	297	403	521	731	877	1029	1250	1316
	1.5	20.4	61	90	20	24	63	104	142	186	252	325	457	548	643	781	822
	1.75	23.8	67	101	20	28	80	95	129	169	230	297	417	500	587	713	751
	2.0	27.2	74	116	21	31	80	85	116	153	207	268	376	451	529	643	677
	2.5	34	96	159	26	38	100	0	90	118	160	207	291	349	409	497	524

- Notes: 1. The data shown above may vary based on elevator specification arrangement.
 2. Earthing wires shall be arranged and installed based on local elevator code requirement.

Work Done by Others

1. Elevator Hoistway Environment

Hoistway Temperature	Hoistway temperature shall be kept from 5 °C (41 °F) to 40 °C (104 °F).
Relative Humidity	<ol style="list-style-type: none"> When a temperature reaches at 40 °C (104 °F), the relative humidity does not go beyond 50%. In the year's most humid month(s), relative humidity shall be kept lower than 90 % and the temperature lower than 25°C (77 °F). Dew condensation prevention measures shall be taken, if there are the possibilities that condensation form inside and on electrical equipment.

2. Electric Power Source

Type of Power Supply	<ol style="list-style-type: none"> Three-Phase Power Supply for Elevator Driving Machine Single-Phase Power Supply for Lighting Equipment
Allowable Error of Voltage Value	The allowable error of voltage value is 7 % above and below the rated voltage.

3. Acceptable Inclination of Hoistway' s Vertical Centerline

Hoistway's Vertical Length	Centerline's Tilt away from the Plumb Line (unit: mm)
30 meter or less	0 to 25 mm or less
more than 30 m up to 60 m or less	0 to 35 mm or less
more than 60 m	0 to 50 mm or less

4. Work done by Others

The following items are in the scope of other contractors' work, not covering all items done by them.

For Hoistway

1.	Construct solid-state, fire-proof elevator hoistway.
2.	Cut out landing walls for Fujitec's installation of elevator operating fixtures and elevator equipment.
3.	Do wall finishing work by filling cement between jambs and landing walls.
4.	Do wall finishing work by filling cement between landing fixtures and landing walls.
5.	Give water-proofing and drainage treatment in elevator pit including the installation of pumping equipment.
6.	Install space divider screens between respective elevators in a hoistway pit.
7.	Install steel separator beams at regular vertical intervals in a hoistway.
8.	When hoistway is constructed with bricks, put steel lintels in its walls for Fujitec's installation of rail brackets. The steel lintels must be completely fixed inside the walls. The vertical height of the lintel is required to be 300 mm or more. For details, see the relevant drawings.

9.	When an elevator traveling distance from a floor to the next is more than 11 m, make an opening on the hoistway wall between the floors and install emergency exit doors in the opening for passenger evacuation.
10.	It is advised that there is no human access to the space below the hoistway pit.
11.	When the bottom of a hoistway pit is deeper than the required level, add backfill concrete up to the required level.
12.	Provide and install a pit ladder based on the layout drawings.
13.	Provide and install a power switching / distributing board in the hoistway.
14.	Provide and install electrical pipes, wires, and leads in the hoistway. They shall be extended from the power switching / distributing board to the controller, machine, and their related apparatuses.
15.	Provide and install all of electricity supply apparatuses (inclusive of pipes, leads, wires, etc.) on various routes from the building's electricity supply system to the hoistway, landing floors and Fujitec-designated locations.
16.	Install air ventilator(s) and/or air conditioner(s) in order to keep the hoistway temperature between 5 °C (41 °F) and 40 °C (104 °F).
17.	Provide and install electrical outlets inside the hoistway.
18.	Install lighting equipment of 30 watt or more at 7-meter intervals inside the hoistway with 0.5-meter clearance at the top and bottom of the hoistway. The lighting intensity is required to be 50 lux or more at the car-top working platform and at the 1-meter high position above the pit bottom.
19.	Make holes in the walls of a hoistway for Fujitec's installation of machine support beams and fill concrete into the gap between the walls and the fixed beams.
20.	Cut out landing walls and install emergency operation panels for Fujitec's emergency access to and operation of elevator machine and brake.
21.	Install machine lifting hooks and / or beams on the hoistway's ceiling slabs. The required lifting load capability is stated on the relevant installation drawings.

1.	Ground-fault circuit interrupter and current leakage alarm are required to be protected against current-harmonic distortion.
2.	Lay building's telecommunication lines 500 mm away from the electric feeder lines for elevator system.
3.	Remove corroded metal materials from the hoistway.
4.	Protect the hoistway against hazardous gas.
5.	Prevent dust from accumulating in the hoistway.
6.	Provide a storage room in order to stock elevator parts and installation materials.
7.	Do not place any tools and materials not related to elevators in the hoistway.

Fujitec Global Operations



Ohio Plant (USA)



Langfang Plant (China)



Shanghai Plant (China)



Korea Plant



Taiwan Plant (China)



Big Wing (Group Headquarters in Japan, Elevator Plant)



Singapore Plant



India Plant



North & South America

- FUJITEC AMERICA, INC.
- FUJITEC CANADA, INC.
- FUJITEC VENEZUELA C.A.
- FUJITEC ARGENTINA S.A.
- FUJITEC URUGUAY S.A.

Japan

- FUJITEC CO., LTD.

East Asia

- FUJITEC (HK) CO., LTD.
- FUJITEC TAIWAN CO., LTD.
- FUJITEC KOREA CO., LTD.
- HUASHENG FUJITEC ELEVATOR CO., LTD.
- SHANGHAI HUASHENG FUJITEC ESCALATOR CO., LTD.
- FUJITEC SHANGHAI TECHNOLOGIES CO., LTD.
- FUJITEC SHANGHAI SOURCING CENTER CO., LTD.

Europe & Middle East

- FUJITEC UK LTD.
- FUJITEC SAUDI ARABIA CO., LTD.
- FUJITEC EGYPT CO., LTD.

South Asia

- FUJITEC SINGAPORE CORPN. LTD.
- FUJITEC INC. (PHILIPPINES)
- FUJITEC (MALAYSIA) SDN. BOD.
- P.T. FUJITEC INDONESIA
- FUJITEC VIETNAM CO., LTD.
- FUJITEC INDIA PRIVATE LTD.
- FUJITEC (THAILAND) CO., LTD.
- FUJITEC LANKA (PRIVATE) LTD.
- FUJITEC PACIFIC, INC. (GUAM)
- FUJITEC MYANMAR CO., LTD.

FUJITEC
www.fujitec.com

REXIA-D

Machine-Room-Less Elevator